

t-NEXT DL DX

8 – 43 kW

**Direct expansion air conditioners for IT Cooling.
To be matched with remote air-cooled condenser.**



 EC FAN

 R HFC R410A

 DISPLACEMENT

The picture of the unit is indicative and may vary depending on the model

- PERIMETER INSTALLATION
- FULLY HERMETIC ON/OFF COMPRESSORS
- SINGLE REFRIGERANT CIRCUIT
- DISPLACEMENT AIR DELIVERY
- PLUG FANS WITH EC ELECTRIC MOTOR
- ELECTRONIC EXPANSION VALVE
- AIR SUCTION TEMPERATURE UP TO 40°C

Data Book: T_tNEXTDLDX_1118_EN

INDEX

MEHITS CERTIFICATIONS.....	3
GENERAL CHARACTERISTICS	4
INSTALLATION.....	4
DISPLACEMENT AIR DELIVERY.....	5
PRODUCT FEATURES AND BENEFITS.....	5
F-GAS DIRECTIVE	5
MODEL IDENTIFICATION.....	5
WORKING LIMITS.....	6
STORING TEMPERATURE.....	6
MAIN COMPONENTS.....	7
OPTIONAL ACCESSORIES.....	9
TECHNICAL DATA	10
REFRIGERANT CHARGE.....	12
REFRIGERANT CIRCUIT.....	12
RECOMMENDED REFRIGERANT LINES.....	13
INSTALLATION DIAGRAM.....	14
ACOUSTIC DATA.....	15
ELECTRICAL DATA.....	15
MICROPROCESSOR CONTROL SYSTEM.....	16
OPTIONAL ACCESSORIES – REMOTE AIR-COOLED CONDENSER “T-MATE”.....	18
OPTIONAL ACCESSORIES – SOFT STARTER SYSTEM.....	20
OPTIONAL ACCESSORIES - CONDENSATE DISCHARGE PUMP.....	21
OPTIONAL ACCESSORIES – MODULATING STEAM HUMIDIFIER.....	22
OPTIONAL ACCESSORIES – DEHUMIDIFICATION SYSTEM.....	23
OPTIONAL ACCESSORIES – ELECTRIC HEATERS.....	24
OPTIONAL ACCESSORIES – EPM ₁₀ 50% EFFICIENCY AIR FILTERS.....	25
OPTIONAL ACCESSORIES - FLOOR STAND.....	25
OPTIONAL ACCESSORIES – DIRECT FREE-COOLING PLENUM.....	26
OPTIONAL ACCESSORIES – KIPLINK – KEYBOARD IN YOUR POCKET.....	29
OPTIONAL ACCESSORIES – CLOUD PLATFORM: WEB SERVICES BASED ON CLOUD TECHNOLOGY FOR REMOTE MONITORING AND MANAGEMENT OF AIR CONDITIONING PLANTS.....	30
MACHINE DRAWINGS.....	31

MEHITS CERTIFICATIONS



SYSTEM CERTIFICATIONS

ISO 9001 CERTIFICATION – MEHITS S.p.A.
Quality Management System

ISO 14001 CERTIFICATION – MEHITS S.p.A.
Environmental Management System

BS OHSAS 18001 CERTIFICATION – MEHITS S.p.A.
Occupational Health and Safety Management System



PRODUCT CERTIFICATIONS BY COUNTRY

CE MARKING
MEHITS units are in compliance with the European Directives in force.

CCC – CQC CERTIFICATION
(People’s Republic of China)

EAC CERTIFICATION
(Russian Federation, Belarus, Kazakhstan)



GENERAL CHARACTERISTICS



Displacement air delivery



Air cooled direct expansion air conditioners for IT Cooling for matching with remote air cooled condenser.

This series is offered in 11 models, all available with displacement air delivery:

Cooling capacity: 8 ÷ 43 kW

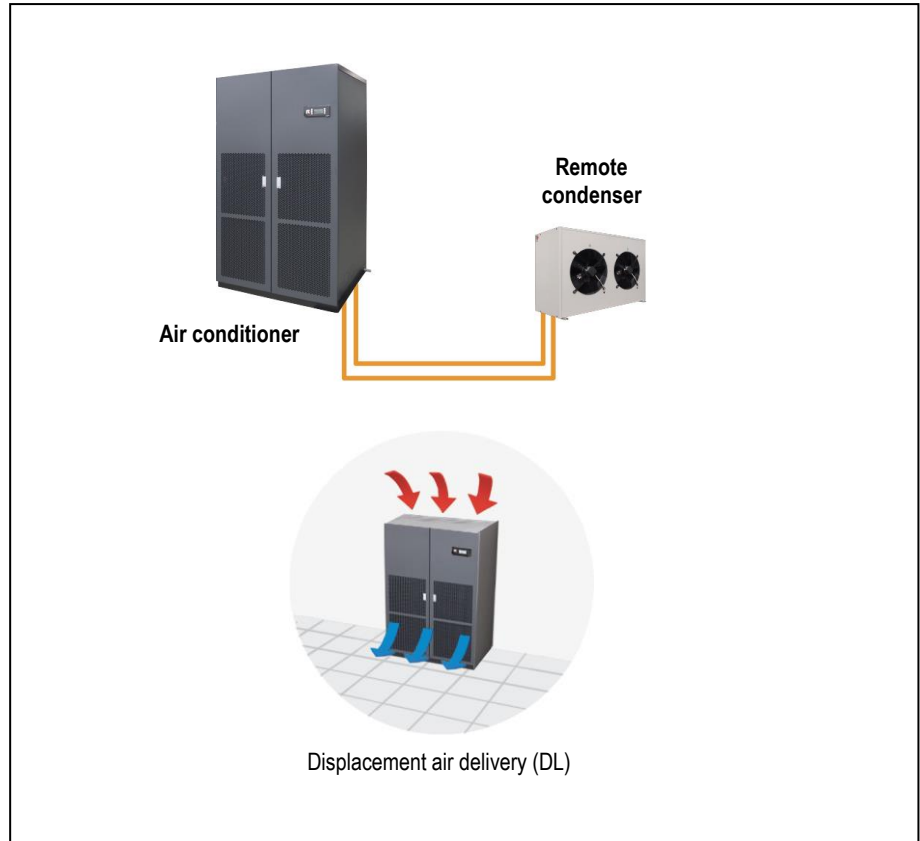

The machines are made for indoor installation.

The constructive solutions and the internal lay-out allow high application flexibility and the frontal access to the main components for the inspection and routine maintenance.

The installation requires refrigerant charge, electrical and hydraulic connections.

Final assembly on all machines before shipment including running test, reading and monitoring of operating parameters, alarms simulation and visual check.

INSTALLATION

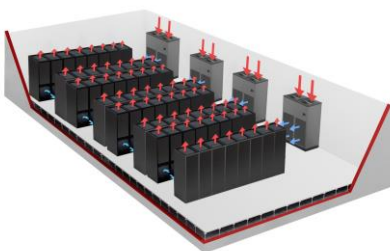

The series is particularly suitable for installation in Data Centre of medium / small size with constant load, which is planned to DISPLACEMENT air delivery.

DISPLACEMENT AIR DELIVERY

Typical installation is on the perimeter.

The units are placed along the walls. Air suction from the top of the unit and frontal air delivery in for the cooling of the racks.

The hot air is expelled from the racks at the top, and then aspirated again from the air conditioner.

OPTIONAL

An extensive list of accessories allows the unit to adapt effectively to the real needs of the system, reducing the time and cost of installation.

DISPLACEMENT AIR DELIVERY

AIR CONDITIONING SYSTEM WITH DISPLACEMENT AIR DELIVERY

The basic concept of the air conditioning system with displacement air delivery is based on the natural convection principle, where the cold air is at the lower ambient zones, while the hot air is at the higher ones. This concept has been developed and applied for the air conditioning in Data Center, Telephone Exchangers and Hi-Tech. facilities.

The air conditioning system with displacement air delivery supplies the cold air directly into the room at low air speed and intakes the air from the top side of the conditioner where the air temperature is higher. The air circulation in the rack can take place in a natural way, or through proper internal fans.

This system, together with the low air distribution speed, causes a strong stratification of the air with temperature differences of about 10°C between the coldest part and the warmest part.

For example, we can consider a temperature condition of 22°C close to the floor and 32°C close to the ceiling with a mean temperature of 26°C at 1,7m height from the floor.

By hot air suction in the higher ambient zone, the air conditioner remarkably increases both the thermodynamic performance and the efficiency, with consequent working conditions and energy consumption optimization.

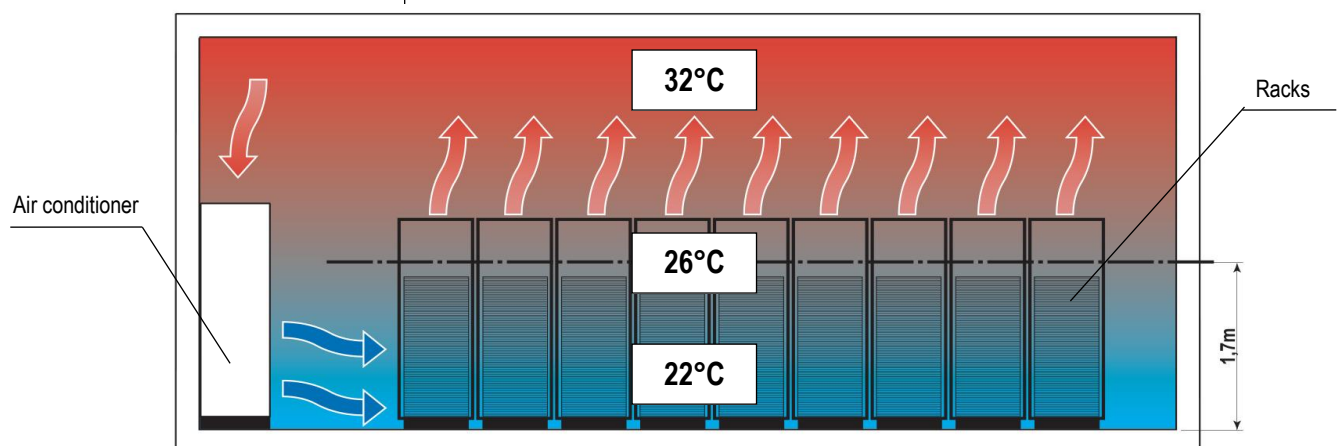

PRODUCT FEATURES AND BENEFITS

- EER up to 5,10;
- New plug fans with EC electric motors and impeller in composite material, which guarantees a reduction of power consumption;
- New fans electric motor that do not require maintenance;
- Improvement of the control software with advanced control logic;
- Hinged frontal panels and lateral panels fully removable to facilitate the operations of extraordinary maintenance;

F-GAS DIRECTIVE

The units highlighted in this publication contain <HFC R410A [GWP₁₀₀ 2088]> fluorinated greenhouse gases.

MODEL IDENTIFICATION

Air conditioners for IT Cooling

t-NEXT DL DX 016 P1 E2

t-NEXT	Series identification
DL	Displacement air delivery
DX	Direct expansion, air cooled
016	Cooling capacity (kW) at nominal conditions
P1	Number and type of compressors
	P = scroll compressor for R401A
	1 = number of compressors
E2	Cabinet size



WORKING LIMITS

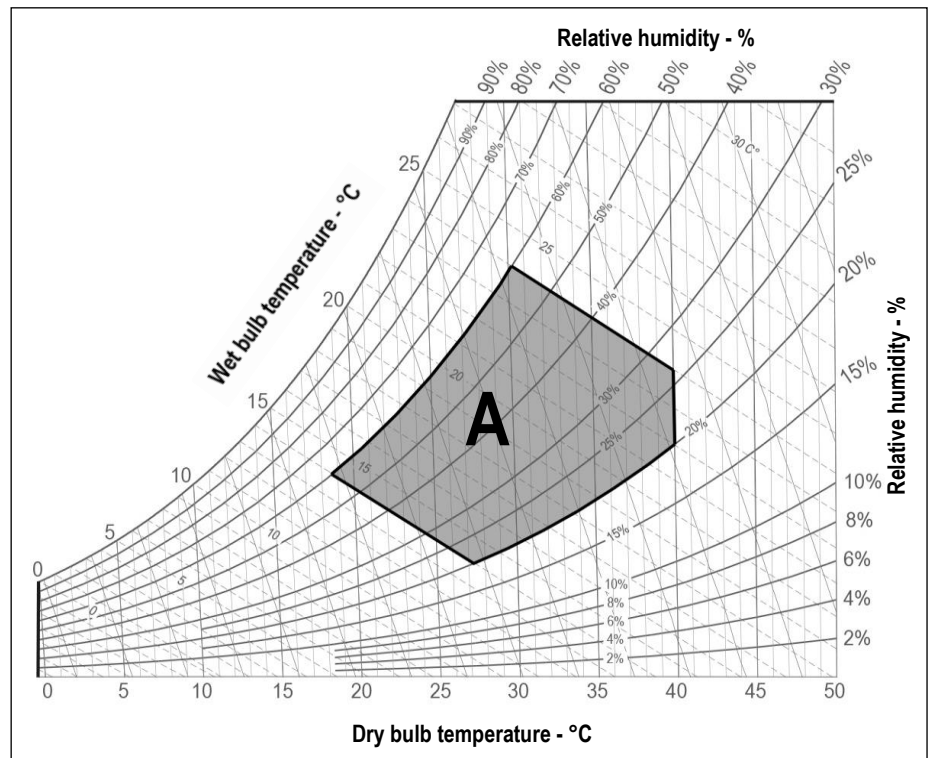

ROOM AIR CONDITIONS

Room air temperature:

14°C	minimum temperature with wet bulb.
24°C	maximum temperature with wet bulb.
18°C	minimum temperature with dry bulb.
40°C	maximum temperature with dry bulb.

AREA "A". Machine operating envelope.

Room air humidity:

20%RH	minimum relative humidity.
60%RH	maximum relative humidity.

AMBIENT AIR TEMPERATURE

45°C	Maximum ambient air temperature
-15°C	Minimum ambient air temperature

All the values are indicative. The working temperatures are influenced by a series of variables as:

- Working conditions;
- Thermal load;
- Set of the microprocessor control.

POWER SUPPLY

± 10%	Maximum tolerance of the supply voltage (V)
± 2%	Maximum unbalancing of the phases.

STORING TEMPERATURE

If the machine is not installed on receipt and is stored for a long time, store it in a protected place, at temperatures ranging between -30°C and 50°C in absence of superficial condensation and direct sun light.

MAIN COMPONENTS



FRAMEWORK

- Base in aluminium extrusion, painted with epoxy powders. Colour RAL 9005;
- Frame in aluminium profile, painted with epoxy powders. The inner frame is provided with seals for the panels. Colour RAL 9005;
- Panels in galvanized steel sheet with protective surfaces treatment in compliance with UNI ISO 9227/ASTMB117 and ISO 7253, and painted with epoxy powders. Colour RAL 7016 hammered;
- Panels insulated with polyurethane foam and seals to ensure air tight.
- Hinged front panels with quick release removal system.
- Total front access for routine maintenance.
- Removable lateral and back side panels.
- Air flow:
 - Air intake from the top and frontal air delivery through honeycomb type grille.
- Compartment for electrical panel on unit front for direct access to control and regulation devices;

FILTER SECTION

- Washable air filters with COARSE 60% efficiency (according to ISO EN 16890) with cells in synthetic fibre and metallic frame;
- Differential pressure switch on the air side for clogged filters alarm signal.
- Frontal air filters access:

ON / OFF COMPRESSORS SECTION

Units size E1 and E2:

- Rotary vane compressors for R410A refrigerant
- 2-pole 3-phase electric motor with direct on line starting.
- Crankcase heater.
- Rubber supports.

Units size E3 e E4:

- Scroll rotary compressors with spiral profile optimized for R410A refrigerant.
- 2-pole 3-phase electric motor with direct on line starting.
- Crankcase heater.
- Rubber supports.

COOLING SECTION

- Heat exchanger coil with internally corrugated copper tubes and high efficiency aluminium fins, specifically developed to provide high heat transfer and lower pressure drops.
- Frame in galvanized steel or peralluman.
- Condensate tray in peralluman with PVC flexible discharge pipe.
- Temperature sensors on air intake with control and regulation functions.
- Temperature sensors on air delivery with function of temperature display.
- Under floor water alarm through sensor to be placed on the floor.



REFRIGERANT CIRCUIT

Components for each refrigerant circuit:

- Electronic expansion valve. The valve allows high performance and system efficiency thanks to a timely and accurate response to changes in temperature and pressure
- Sight glass.
- Filter dryer on liquid line.
- Pressure transducers with indication, control and protection functions, on low and high refrigerant pressure.
- High pressure safety switch with manual reset.
- Liquid receiver with accessories.
- Refrigerant circuit with copper tubing with anticondensate insulation of the suction line.
- R410A refrigerant charge and lubricant oil.
- Valves on gas delivery and liquid return for coupling to remote air cooled condenser.
- 0-10V proportional signal to manage the condensing control system of the remote air cooled condenser.

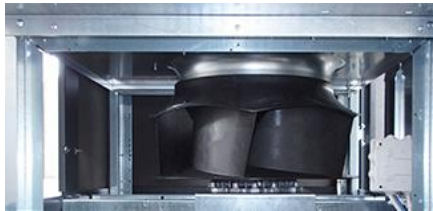

FANS SECTION

The fan section is contained within the machine and includes:

- Centrifugal fans with backward curved blades with wing profile, single suction and without scroll housings (Plug-fans), directly coupled to external rotor electric motor.
- Impeller in composite material exempt from rust formation.
- Brushless type synchronous EC motor with integrated electronic commutated system and continuous variation of the rotation speed. The motor rotation control is obtained with the EC system (Electronic Commutation) that manage the motor according to the signal coming from the microprocessor control.
- Fans control through ModBus. In case of failure, the control stops the interested fan indicating the type of fault. The machine with more than one fan is not stopped.



ELECTRICAL PANEL

In accordance with EN60204-1 norms, suitable for indoor installation, complete with:

- Main switch with door lock safety on frontal panel.
 - Magnetothermic switches for supply fans. The supply fans equipped with EC electric motor and don't require contactors.
 - Transformer for auxiliary circuit and microprocessor supply.
 - Terminals:
- OUTLETS
- Voltage free deviating contact for General Alarm 1-2.
 - Voltage free contact for supply fans status.
- INLETS
- External enabling.
- Power supply 400/3+N/50.

CONTROL SYSTEM

Microprocessor control system with graphic display for control and monitor of operating and alarms status. The system includes:

- Built-in clock for alarms date and time displaying and storing;
- Built-in memory for the storing of the intervened events (up to 200 events recorded);
- Predisposition for additional connectivity board housing (MBUS RS485/JBUS, MBUS RS232/JBUS for GSM modem, LON, BACnet for Ethernet (SNMP- TCP/IP), BACnet for MS/TP). The electronic cards are optional accessories.
- Main components hour-meter;
- Non-volatile "Flash" memory for data storage in case of power supply faulty;
- Menu with protection password;
- LAN connection (max 10 units).



OPTIONAL ACCESSORIES

The descriptions of these additional components can be found in Chapter OPTIONAL ACCESSORIES.

- Remote air-cooled condensers:
 - with AC axial fans series T-MATE DX-A;
 - with EC axial fans series T-MATE DX-E;
 - with EC plug-fans series T-MATE DX-PF-E.
- Compressor motor soft-starter system (size E1, E2 excluded). The system is contained in the electrical box. Its function is to reduce the starting current of the motor with a monitored start.
- Condensate drain system. Supplied in mounting kit. The system includes pump with activation float and 10 linear meters long discharge pipe.
- Modulating steam humidifier with immersed electrodes with electronic control (size E1, E2 excluded). The optional foresee the combined Temperature / Humidity sensor on return air.
- Dehumidification system. The optional foresee the electronic expansion valve and the combined Temperature / Humidity sensor on return air.
- Electric heating system consisting of aluminium armoured elements with integral fins
- Washable air filter with ePM₁₀ 50% efficiency (according to ISO EN 16890).
- Plenum for direct free-cooling on air intake. The optional foresee the combined Temperature / Humidity sensor on machine air suction and the Temperature sensor for ambient air.
- KIP LINK: Keyboard in your pocket. Allows to operate on the unit with smartphone or tablet.
- CLOUD PLATFORM: Web services based on cloud technology for remote monitoring and management.

OTHER ACCESSORIES

- Solenoid valve on liquid line. Recommended for refrigeration pipe with lines exceeding 10 m.
- Compressor soundproof cap for a sound level reduction of 2 dB(A).
- Additional underfloor water sensor kit.
- Voltage free contact for compressor run signal.
- Compressors capacitor for power factor - $\cos\phi$ 0,9.
- Remote temperature sensor for the compensation of the return air set-point. Each conditioner can be wired to an additional probe to measure the room temperature in a determinate point of the room. These additional probes must be used only if strictly requested.

We suggest two types of usage:

- The presence of a highly temperature sensitive device and/or with a thermal load higher than the average. In this situation the probe should be placed close to the device and wired to the nearest conditioner.
- Some particular situations of the room lay-out
- Combined Temperature / Humidity sensor on return air.
- Temperature sensor for outdoor installation.
- Combined Temperature / Humidity sensor for remote installation. The optional is added to the standard sensor on machine air suction.
- Microprocessor control accessories:
 - Remote terminal.
 - Serial card MBUS RS485/JBUS.
 - Scheda seriale MBUS RS232/JBUS per modem GSM.
 - Serial card LON.
 - Serial card BACnet for Ethernet – SNMP – TCP/IP.
 - Serial card BACnet for MS/TP.
 - Temporary microprocessor power supply. The system guarantees the microprocessor power supply for a few minutes, in case of supply voltage failure.
 - Analogue set point compensation according to an external analogue signal at Customer care.
The microprocessor control, through the additional module “expansion card”, can manage a compensation signal of the return air setpoint by analogue input (0...1V; 0...5V; 0,5...4,5V; 4...20mA; 0...20mA). The compensation curve allows to assign a temperature setpoint offset respectively to the minimum and maximum signal managed by the input.

WARNING

The Manufacturer reserves the right to accept the matching of the optional installed on the machine.

TECHNICAL DATA

MODEL		007 P1	009 P1	011 P1	014 P1	016 P1	020 P1
SIZE		E1	E1	E1	E2	E2	E3
VERSION (1)		DL	DL	DL	DL	DL	DL
COOLING CAPACITY (2)							
Total	kW	7,63	9,18	10,6	14,1	15,1	20,5
Sensible	kW	7,54	9,02	10,3	13,8	14,8	20,5
SHR (3)		0,99	0,98	0,97	0,98	0,98	1
Total power input (Comp. + Fans)	kW	1,59	1,98	2,43	3,01	3,42	4,02
"EC" SUPPLY FANS							
Air flow	m ³ /h	2000	2160	2240	3200	3360	4560
Nominal external static pressure	Pa	20	20	20	20	20	20
Maximum external static pressure	Pa	263	238	225	529	514	1000
Fans power input (4)	kW	0,11	0,13	0,14	0,24	0,27	0,35
ON/OFF COMPRESSORS		rotary vane	rotary vane	rotary vane	rotary vane	rotary vane	scroll
Compressors number	n.	1	1	1	1	1	1
Capacity steps	n.	1	1	1	1	1	1
Compressors power input	kW	1,48	1,85	2,29	2,76	3,16	3,67
AIR FILTERS		n.	1	1	1	1	2
Efficiency (ISO EN 16890)	COARSE	60%	60%	60%	60%	60%	60%
REFRIGERANT CIRCUITS		n.	1	1	1	1	1
POWER SUPPLY	V/Ph/Hz	400/3+N/50	400/3+N/50	400/3+N/50	400/3+N/50	400/3+N/50	400/3+N/50
ENERGY EFFICIENCY INDEX (2) (5)							
EER Energy Efficiency Ratio	kW/kW	4,8	4,64	4,36	4,68	4,42	5,1
DIMENSIONS							
Length	mm	650	650	650	785	785	1085
Width	mm	675	675	675	675	675	775
Height	mm	1925	1925	1925	1925	1925	1925
NET WEIGHT	kg	220	221	225	260	263	320
REFRIGERANT CONNECTIONS							
Gas delivery	ODS Ø	12	12	12	16	16	16
Liquid return	ODS Ø	12	12	12	12	12	16
HYDRAULIC CONNECTIONS							
Condensate discharge - rubber pipe	F Ø	1/2"	1/2"	1/2"	1/2"	1/2"	1/2"

THE COOLING CAPACITY DOES NOT CONSIDER THE SUPPLY FAN MOTOR THERMAL LOAD

1. DL = Displacement air delivery
2. Gross value. Characteristics referred to entering air at 30°C-30%RH; condensing temperature 45°C. ESP=20Pa.
3. SHR = Sensible Cooling Capacity / Total Cooling Capacity
4. Corresponding to the nominal external static pressure
5. The Energy Efficiency Index does not consider the remote air cooled condenser.

The units highlighted in this publication contain <HFC R410A [GWP₁₀₀ 2088]> fluorinated greenhouse gas

TECHNICAL DATA

MODEL		022 P1	026 P1	032 P1	037 P1	041 P1
SIZE		E3	E3	E4	E4	E4
VERSION (1)		DL	DL	DL	DL	DL
COOLING CAPACITY (2)						
Total	kW	22,4	26,7	34,6	38,5	42,6
Sensible	kW	22,3	26	33	38	41,8
SHR (3)		1	0,97	0,95	0,99	0,98
Total power input (Comp. + Fans)	kW	4,85	5,99	6,89	8,14	8,96
"EC" SUPPLY FANS						
	n.	1	1	1	1	1
Air flow	m³/h	4880	5120	6960	8000	8640
Nominal external static pressure	Pa	20	20	20	20	20
Maximum external static pressure	Pa	1000	991	871	709	762
Fans power input (4)	kW	0,4	0,45	0,69	0,99	0,87
ON/OFF COMPRESSORS						
		scroll	scroll	scroll	scroll	scroll
Compressors number	n.	1	1	1	1	1
Capacity steps	n.	1	1	1	1	1
Compressors power input	kW	4,45	5,54	6,2	7,15	8,09
AIR FILTERS						
	n.	2	2	2	2	2
Efficiency (ISO EN 16890)	COARSE	60%	60%	60%	60%	60%
REFRIGERANT CIRCUITS						
	n.	1	1	1	1	1
POWER SUPPLY						
	V/Ph/Hz	400/3+N/50	400/3+N/50	400/3+N/50	400/3+N/50	400/3+N/50
ENERGY EFFICIENCY INDEX (2) (5)						
EER Energy Efficiency Ratio	kW/kW	4,62	4,46	5,02	4,73	4,75
DIMENSIONS						
Length	mm	1085	1085	1305	1305	1305
Width	mm	775	775	930	930	930
Height	mm	1925	1925	2165	2165	2165
NET WEIGHT						
	kg	320	322	420	425	440
REFRIGERANT CONNECTIONS						
Gas delivery	ODS Ø	16	18	22	22	22
Liquid return	ODS Ø	16	16	16	16	22
HYDRAULIC CONNECTIONS						
Condensate discharge - rubber pipe	F Ø	1/2"	1/2"	1/2"	1/2"	1/2"

THE COOLING CAPACITY DOES NOT CONSIDER THE SUPPLY FAN MOTOR THERMAL LOAD

1. DL = Displacement air delivery
2. Gross value. Characteristics referred to entering air at 30°C-30%RH; condensing temperature 45°C. ESP=20Pa.
3. SHR = Sensible Cooling Capacity / Total Cooling Capacity
4. Corresponding to the nominal external static pressure
5. The Energy Efficiency Index does not consider the remote air cooled condenser.

The units highlighted in this publication contain <HFC R410A [GWP₁₀₀ 2088]> fluorinated greenhouse gas

REFRIGERANT CHARGE

The air conditioner is supplied with a minimum R410A refrigerant charge. **Refrigerant must be charged.** The following table shows the refrigerant charge that must be introduced for the air conditioner only. Remote condenser, connections pipes and optional are excluded.

MODEL		007 P1	009 P1	011 P1	014 P1	016 P1	020 P1
SIZE		E1	E1	E1	E2	E2	E3
VERSION (1)		DL	DL	DL	DL	DL	DL
REFRIGERANT		R410A	R410A	R410A	R410A	R410A	R410A
Refrigerant circuits x Refrigerant charge (2)	n x kg	1 x 3,2	1 x 3,2	1 x 3,2	1 x 3,4	1 x 3,4	1 x 4,0
HFC R410A - F Gas - CO ₂ equivalent	t	6,68	6,68	6,68	7,09	7,09	8,35

MODEL		022 P1	026 P1	032 P1	037 P1	041 P1
SIZE		E3	E3	E4	E4	E4
VERSION (1)		DL	DL	DL	DL	DL
REFRIGERANT		R410A	R410A	R410A	R410A	R410A
Refrigerant circuits x Refrigerant charge (2)	n x kg	1 x 4,0	1 x 4,0	1 x 5,7	1 x 5,7	1 x 8,6
HFC R410A - F Gas - CO ₂ equivalent	t	8,35	8,35	11,9	11,9	17,95

- DL = Displacement air delivery
- Refrigerant charge required for the air conditioner only operation. Remote condenser, connections pipes and optional are excluded.

REFRIGERANT CIRCUIT

The diagrams refer to the standard configuration, without optional.

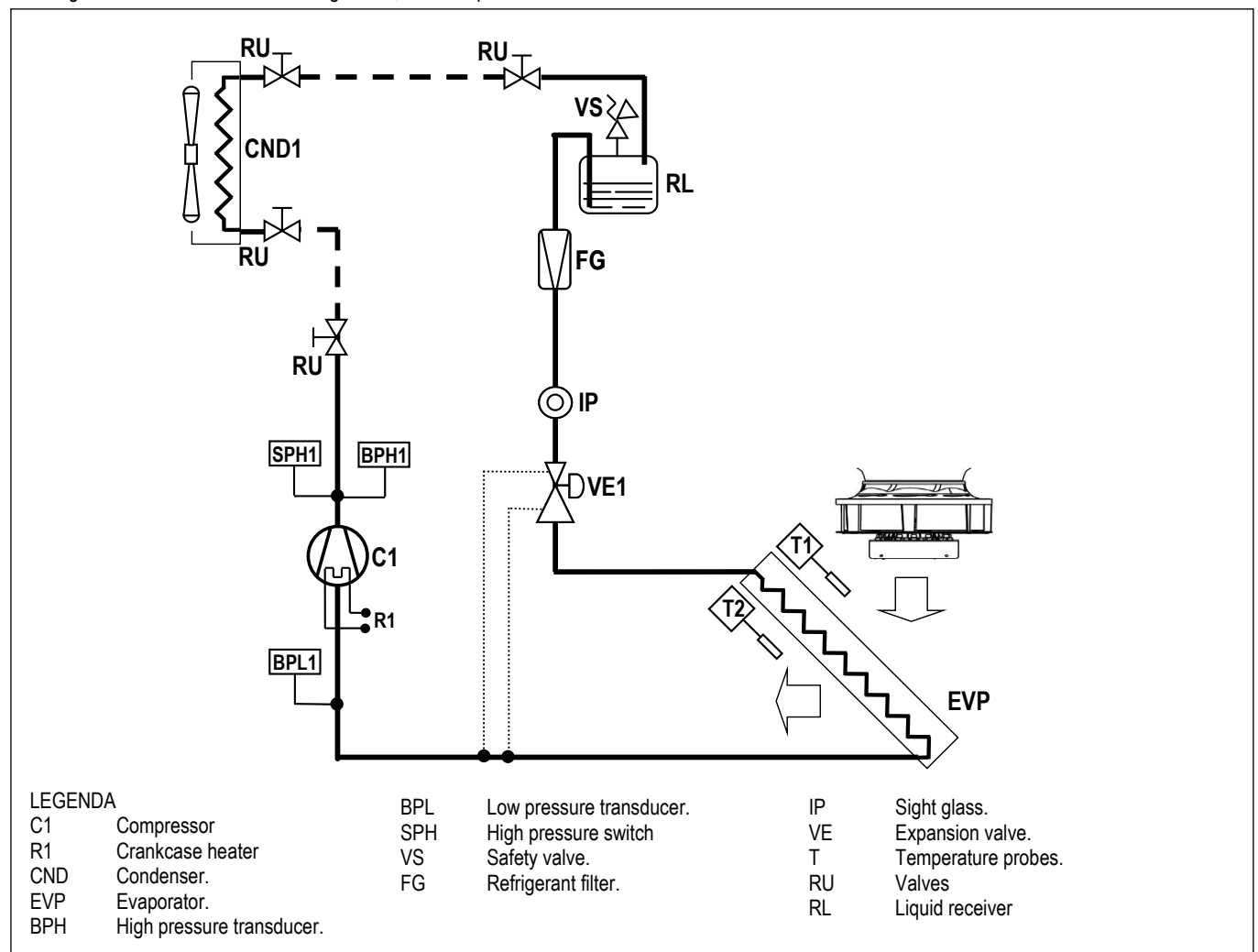

RECOMMENDED REFRIGERANT LINES

Values are referred to "EQUIVALENT LENGTH" of the piping.

You are kindly requested to always refer to the "INSTALLATION DIAGRAM" for the allowable height difference and to properly select all necessary components

Verify the need to use pressure limiting devices (safety valves) where not already provided for by Directive 2014/68 / EU.

Model	Capacity for single circuit [kW]	Line	Nominal Ø [mm]	EQUIVALENT LENGTH [m] FOR ON / OFF COMPRESSORS R410A									
				5	10	15	20	25	30	35	40	45	50
007 P1 S	7	Gas	12	12 mm									16 mm
		Liquid	12	12 mm									
009 P1 S	9	Gas	12	12 mm					16 mm				
		Liquid	12	12 mm									16 mm
011 P1 S	11	Gas	12	12 mm				16 mm					
		Liquid	12	12 mm					16 mm				
014 P1 S	14	Gas	16	16 mm									
		Liquid	12	12 mm				16 mm					
016 P1 S	16	Gas	16	16 mm									
		Liquid	12	12 mm			16 mm						
020 P1 S	20	Gas	16	16 mm					18 mm				
		Liquid	16	16 mm									
022 P1 S	22	Gas	16	16 mm					18 mm				
		Liquid	16	16 mm									18 mm
026 P1 S	26	Gas	22	22 mm									
		Liquid	16	16 mm					18 mm				
032 P1 S	32	Gas	22	22 mm									
		Liquid	16	16 mm				18 mm				22 mm	
037 P1 S	37	Gas	22	22 mm									
		Liquid	16	16 mm			18 mm			22 mm			
041 P1 S	41	Gas	22	22 mm									
		Liquid	22	22 mm									

For equivalent lengths over 50m, please contact the Manufacturer's Sales Office.

INSTALLATION DIAGRAM

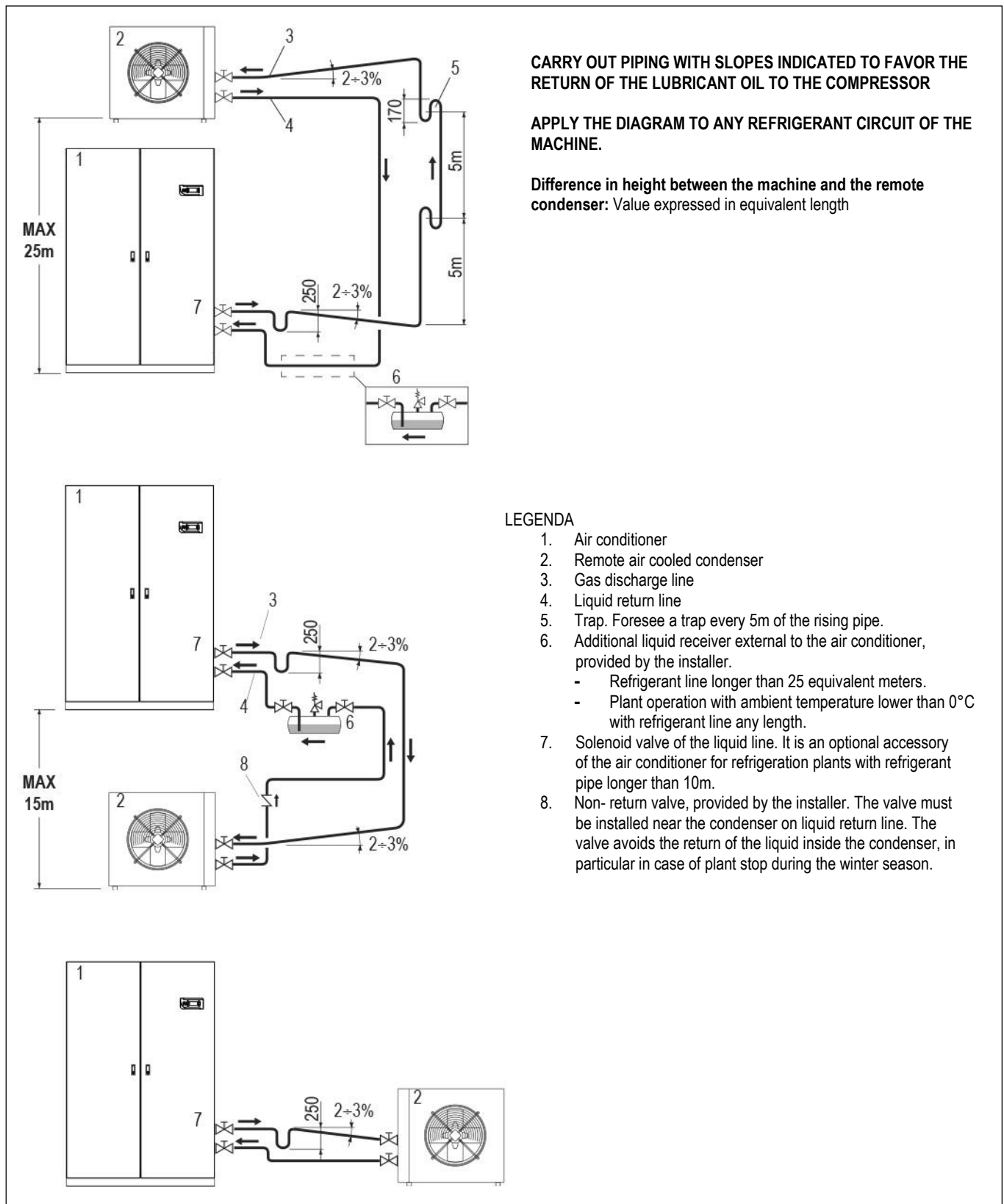

WARNING

It is necessary to provide the refrigerant charge for the connection pipes and for the remote air-cooled condenser. Charge refrigerant in the suitable quantity and lubricant oil in 10% ratio of charged refrigerant. Lubricant oil must be the same type as the charged one as shown on the compressor plate.

ACOUSTIC DATA

Acoustic data of the standard machine at full load working conditions.

WARNING:

In a closed room the noise produced by a sound source reaches the listener in two different ways:

- Directly
- Reflected from the surrounding walls, floor, ceiling, from furniture.

With the same sound source, the noise produced in a closed room is greater than that produced outdoors. In fact, the sound pressure level generated by the source, must be added to the one reflected from the room. Also, the shape of the room affects the sound.

MODEL		007 P1	009 P1	011 P1	014 P1	016 P1	020 P1
SIZE		E1	E1	E1	E2	E2	E3
VERSION (1)		DL	DL	DL	DL	DL	DL
SOUND LEVEL ISO 3744 (2)							
On unit front	dB(A)	50	50	52	52	54	54

MODEL		022 P1	026 P1	032 P1	037 P1	041 P1
SIZE		E3	E3	E4	E4	E4
VERSION (1)		DL	DL	DL	DL	DL
SOUND LEVEL ISO 3744 (2)						
On unit front	dB(A)	58	56	59	61	60

1. DL = Displacement air delivery
2. Noise pressure level at 1 meter in free field – ISO 3744

ELECTRICAL DATA

MODEL		007 P1	009 P1	011 P1	014 P1	016 P1	020 P1
SIZE		E1	E1	E1	E2	E2	E3
VERSION (1)		DL	DL	DL	DL	DL	DL
Power supply	V/ph/Hz	400/3+N/50	400/3+N/50	400/3+N/50	400/3+N/50	400/3+N/50	400/3+N/50
Maximum current input (FLA)	A	3,83	4,63	5,73	8,3	8,9	16

MODEL		022 P1	026 P1	032 P1	037 P1	041 P1
SIZE		E3	E3	E4	E4	E4
VERSION (1)		DL	DL	DL	DL	DL
Power supply	V/ph/Hz	400/3+N/50	400/3+N/50	400/3+N/50	400/3+N/50	400/3+N/50
Maximum current input (FLA)	A	19,2	20,4	22,4	25,8	29,4

1. DL = Displacement air delivery

WARNING:

The electric data indicated refer only to the indoor unit.

Optional accessory electric data are included within the dedicated chapters and must be added.

Please refer to ELCA WORLD selection program to calculate the electrical data of the air conditioner according to the requested optional accessories.





The remote air-cooled condenser is not included because it has independent power supply.

MICROPROCESSOR CONTROL SYSTEM

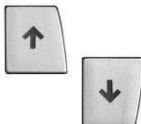

The microprocessor control system is equipped with 6 keys terminal and back lighted graphic display on which all information in different languages or easily identifiable symbols are displayed. The system disposes of a "flash" memory that preserves the information even in absence of power supply. Part of memory is dedicated to the registration of intervened events - up to 200 events.

KEYBOARD FUNCTIONS

	ALARM	Alarm, Back-red light active – alarm presence, push to have alarm description. If more than one alarm(s), the others can be scrolled by Key UP / DOWN
	PRG	Menu list, scrolled by key UP/DOWN: Unit; Set-point; In/Out; Clock; History; User; Service; Factory. Use the ENTER key to execute the mode.
	ESC	Home. Used to come back to the previous menu level or to the main screen.
	UP DOWN	Used to change the pages and values of sets. When display is in main screen (HOME), pressing one of them (UP/DOWN) will display the synoptic of the main controls.
	ENTER	Moving the cursor on adjustable Program(s) fields, to confirm the changes, press the key (ENTER) to get out of the fields.

CONNECTIVITY

Through the optional serial port, the microprocessor control enables communication with the modern buildings BMS systems with the following protocols:

- MBUS/JBUS (RS485) serial card;
- MBUS/JBUS (RS232) for GSM modem serial card;
- LON Works serial card;
- BACnet per Ethernet – SNMP – TCP/IP serial card;
- BACnet per MS/TP serial card;

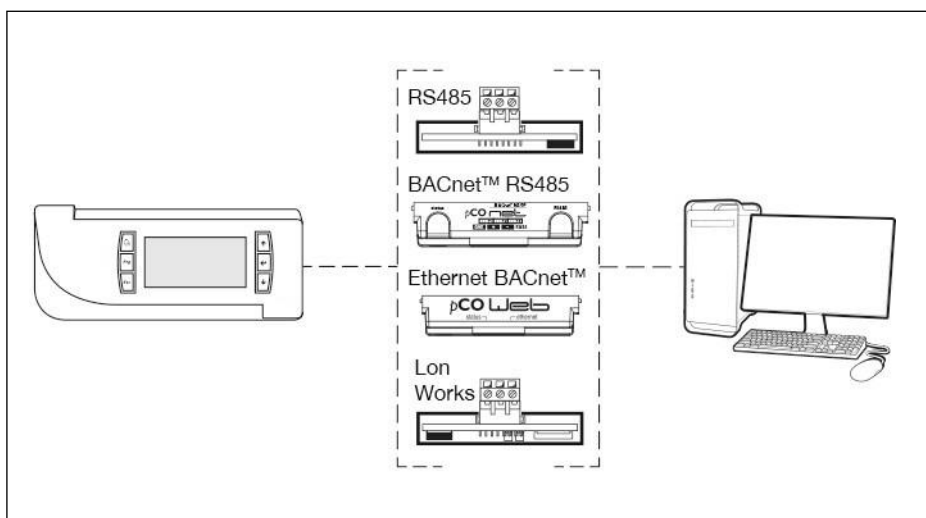

PASSWORD

- Level 1: On request of the End User. Allowing to reach USER menu
- Level 2: Asks to Service: Allowing to reach SERVICE menu
- Level 3: Asks to Service: Allowing to reach FACTORY menu

No passwords request to enter: UNIT, SETPOINT, IN/OUT, CLOCK, HISTORY menu

LAN NETWORK

The LAN is part of the control software and it is possible to connect up to 10 units.

This type of connection allows to control the units in coherent way, moreover the units can be controlled and managed from a shared remote terminal.

Electrical connections are on electrical panel connecting terminals.

LAN ADDRESS LIST

Unit #	1	2	3	4	5	6	7	8	9	10	Remote Terminal
Mother board address	1	2	3	4	5	6	7	8	9	10	--
Terminal address	11	12	13	14	15	16	17	18	19	20	32

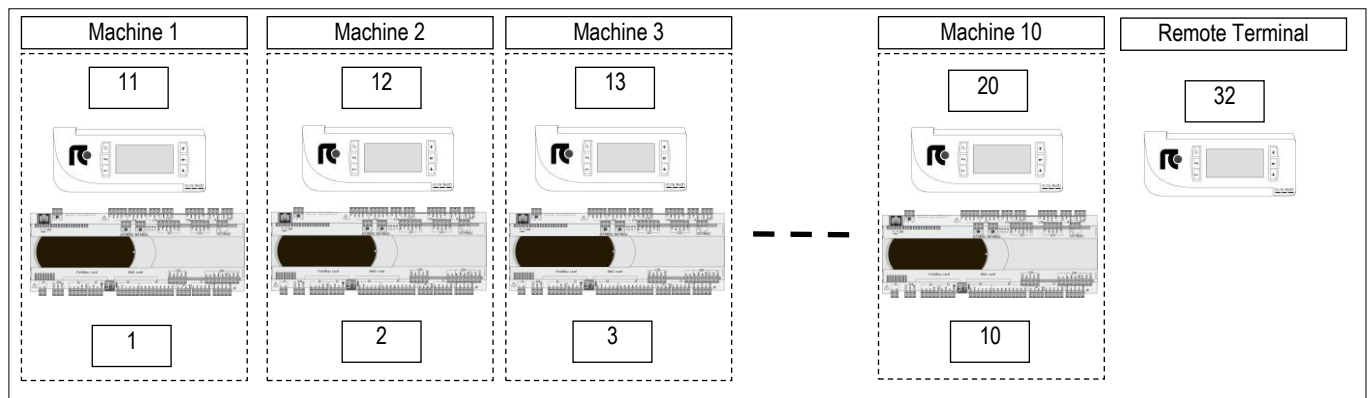

The unit connection to the local network (LAN) allows to perform the following functions:

- Balancing the operating hours among the different units by rotating the reserve units (Stand-by)
- Turning on the reserve units in case other units should turn off due to an alarm, maintenance or power feed interruption
- Turning on reserve units to offset the excessive thermal load
- Checking up to 10 units with a single user terminal (shared user terminal)

OPTIONAL ACCESSORIES – REMOTE AIR-COOLED CONDENSER “T-MATE”

Remote air cooled condensers for matching to air conditioners for IT Cooling.

The constructive solutions allow high application flexibility.

The series has an independent power supply from the indoor unit.

Among the indoor unit and the condenser is necessary the refrigerant and the electrical connection of the condensing proportional control signal and of the alarms.

SERIES IDENTIFICATION



T-MATE DX-A



T-MATE DX-PF-E

T-MATE DX-A: Remote air cooled condensers equipped with AC axial fans with horizontal air flow, from coil to fans.

T-MATE DX-E: Remote air cooled condensers equipped with EC axial fans with horizontal air flow, from coil to fans.

The machines are made with weather resistant materials and suitable for outdoor installation.

Optional accessories:

- Support legs for vertical air flow
- Coil with Blygold treatment
- Coil with Cataphoresis treatment

T-MATE DX-PF-E: Remote air cooled condensers equipped with EC plug fans.

The machines are designed for indoor installation and ducting for air suction and discharge.

For outdoor installation, the machine must be installed under a cover or anyway protected against atmospheric agent.

Optional accessories:

- Coil with Blygold treatment
- Coil with Cataphoresis treatment

The T-MATE series is available in 3 versions:

- STD - No air flow and sound level reduction
- LNO – Air flow reduction at 85% with consequent sound level reduction.
- ELN – Air flow reduction at 70% with further sound level reduction

IMPORTANT

For further information about the units, please refer to “T-MATE” technical bulletin

t-NEXT DL DX

T-MATE DX-A MATCHING

Remote air-cooled condensers equipped with AC axial fans. **For outdoor installation.**

Single phase power supply (V/ph/Hz 230/1/50).

MODEL		007 P1	009 P1	011 P1	014 P1	016 P1	020 P1
SIZE		E1	E1	E1	E2	E2	E3
REMOTE CONDENSER	n	1	1	1	1	1	1
STD version	Mod.	M 11	M 11	M 11	M 14	M 17	M 25
LNO version	Mod.	M 11	M 11	M 14	M 17	M 25	M 30
ELN version	Mod.	M 11	M 11	M 14	M 17	M 25	M 30

MODEL		022 P1	026 P1	032 P1	037 P1	041 P1
SIZE		E3	E3	E4	E4	E4
REMOTE CONDENSER	n	1	1	1	1	1
STD version	Mod.	M 25	M 30	M 35	M 45	M 45
LNO version	Mod.	M 30	M 45	M 45	M 50	M 60
ELN version	Mod.	M 30	M 45	M 45	M 50	M 60

T-MATE DX-E MATCHING

Remote air-cooled condensers equipped with EC axial fans. **For outdoor installation.**

Three phases power supply (V/ph/Hz 380-480/3/50-60).

MODEL		007 P1	009 P1	011 P1	014 P1	016 P1	020 P1
SIZE		E1	E1	E1	E2	E2	E3
REMOTE CONDENSER	n	1	1	1	1	1	1
STD version	Mod.	T 11	T 11	T 11	T 14	T 17	T 25
LNO version	Mod.	T 11	T 11	T 14	T 17	T 25	T 30
ELN version	Mod.	T 11	T 11	T 14	T 17	T 25	T 30

MODEL		022 P1	026 P1	032 P1	037 P1	041 P1
SIZE		E3	E3	E4	E4	E4
REMOTE CONDENSER	n	1	1	1	1	1
STD version	Mod.	T 25	T 30	T 35	T 45	T 45
LNO version	Mod.	T 30	T 45	T 45	T 50	T 60
ELN version	Mod.	T 30	T 45	T 45	T 50	T 60

T-MATE DX-PF-E MATCHING

Remote air-cooled condensers equipped with EC plug fans. **For indoor installation.**

Three phases power supply (V/ph/Hz 380-480/3/50-60).

MODEL		007 P1	009 P1	011 P1	014 P1	016 P1	020 P1
SIZE		E1	E1	E1	E2	E2	E3
REMOTE CONDENSER	n	1	1	1	1	1	1
STD version	Mod.	T 11	T 11	T 11	T 14	T 21	T 24

MODEL		022 P1	026 P1	032 P1	037 P1	041 P1
SIZE		E3	E3	E4	E4	E4
REMOTE CONDENSER	n	1	1	1	1	1
STD version	Mod.	T 24	T 33	T 38	T 44	T 44

WARNING:

Please refer to ELCA WORLD selection program to calculate the cooling capacity of the air conditioner according to the selected remote condenser.

The remote air cooled condenser has independent power supply from the indoor unit.

IMPORTANT

For further information about the units, please refer to "T-MATE" technical bulletins



OPTIONAL ACCESSORIES – SOFT STARTER SYSTEM



The optional is not available for size E1, E2.
Compressor motors soft-starter system.
The system is contained in the electrical box.
Its function is to reduce the starting current of the motor with a monitored start.

The optional temporarily reduces the load in the power circuit and starting current of the motor during start-up. This reduces the mechanical stress and torque on the motor and mechanical parts, as well as the electrodynamic stresses on the power cables and electrical distribution network, extending the lifespan of the system.

MODEL		007 P1	009 P1	011 P1	014 P1	016 P1	020 P1
SIZE		E1	E1	E1	E2	E2	E3
VERSION (1)		DL	DL	DL	DL	DL	DL
ON/OFF COMPRESSORS		rotary vane	rotary vane	rotary vane	rotary vane	rotary vane	scroll
Compressors number	#	-	-	-	-	-	1
Total starting current [LRA]	A	-	-	-	-	-	64
WITH SOFT STARTER							
Total starting current [LRA]	A	-	-	-	-	-	36,8

MODEL		022 P1	026 P1	032 P1	037 P1	041 P1
SIZE		E3	E3	E4	E4	E4
VERSION (1)		DL	DL	DL	DL	DL
ON/OFF COMPRESSORS		scroll	scroll	scroll	scroll	scroll
Compressors number	#	1	1	1	1	1
Total starting current [LRA]	A	75	101	128	139	118
WITH SOFT STARTER						
Total starting current [LRA]	A	46,7	50,6	57,1	67,3	78,6

1. DL = Displacement air delivery

OPTIONAL ACCESSORIES - CONDENSATE DISCHARGE PUMP



A plastic case contains the vertical type pump, the water tank with float plus safety switch and hydraulic and electric connection.

Together the pump 10 linear meters anti-crushing plastic discharge spiral tube is supplied. The optional must be installed as shown in the documentation delivered together with the unit.

Wiring includes power supply and an alarm, displayed on microprocessor, that includes motor pump thermal protection and tank overflow.

The condensate discharge pump operation is fully automatic.

WARNING

For all the machines the optional accessory is supplied in mounting kit.

TECHNICAL DATA

Power supply: 230V~ 50Hz
 Electrical data: 70W – 0,67A
 Maximum water flow: 500 l/h
 Maximum delivery height: 5.0 m
 Sound level: 45dBA a 1 m
 Maximum water temperature: 70°C
 Water acidity: pH>2.5
 Tray volume: 2.0 l
 Protection IP 20

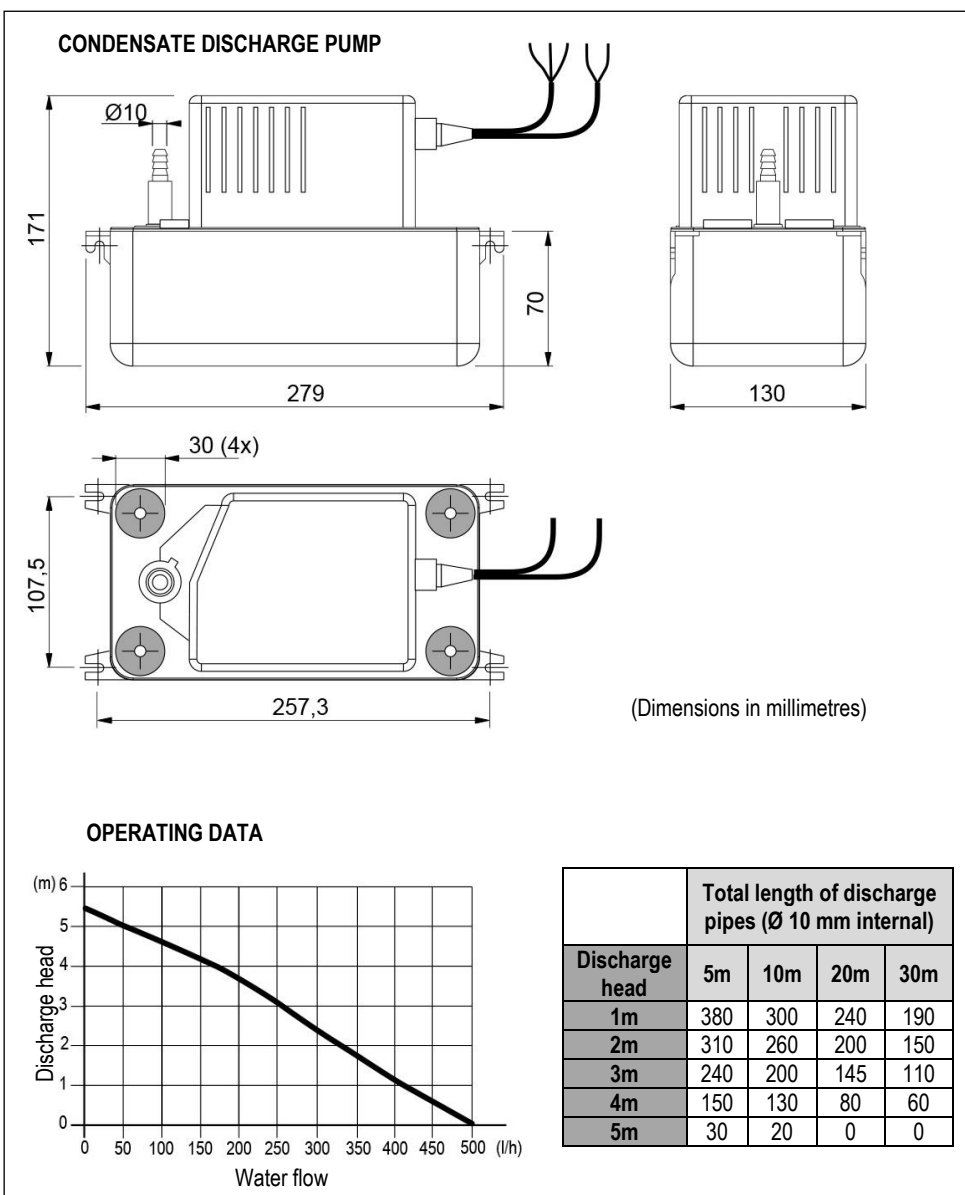

OPTIONAL ACCESSORIES – MODULATING STEAM HUMIDIFIER



Modulating steam humidifier with immersed electrodes fitted with safety and running accessories. The optional is not available for size E1, E2.

The optional includes the combined temperature / humidity sensor on unit air intake.

The accessory is factory installed and requires only water filling connection.

Humidifier water charge and discharge pipes are not supplied.

It is recommended to install a filter and a shut-off valve on the pipe to the water inlet.

This humidifier produces non pressurized steam by electrodes immersed in the water inside the cylinder: they bring the electric phase in the water that works as an electrical resistance and overheats. The steam so produced is distributed with dedicated distributors and used for ambient humidification or for industrial processes.

CHARACTERISTICS OF THE SUPPLY WATER

The quality of the used water influences the evaporation process, so the humidifier can be fed with **not-treated water, only when potable and non-demineralised.**

LIMIT VALUES

		Min	Max
Hydrogen ions	pH	7	8,5
Specific conductivity at 20°C	$\sigma_{R, 20^\circ C}$ $\mu S/cm$	300	1250
Total dissolved solids	TDS mg/l	(1)	(1)
Dry residue at 180°C	R ₁₈₀ mg/l	(1)	(1)
Total hardness	TH mg/l CaCO ₃	100 (2)	400
Temporary hardness	mg/l CaCO ₃	60 (3)	300
Iron + Manganese	mg/l Fe + Mn	0	0,2
Chlorides	ppm Cl	0	30
Silica	mg/l SiO ₂	0	20
Residual chlorine	mg/l Cl ⁻	0	0,2
Calcium sulphate	mg/l CaSO ₄	0	100
Metallic impurities	mg/l	0	0
Solvents, diluents, soaps, lubricants	mg/l	0	0

(1) Values depending on specific conductivity; in general: TDS \cong 0,93 * $\sigma_{R, 20^\circ C}$; R₁₈₀ \cong 0,65 * $\sigma_{R, 20^\circ C}$

(2) Not lower than 200% of the chloride content in mg/l di Cl⁻

(3) Not lower than 300% of the chloride content in mg/l di Cl⁻

WARNING:

- No relation can be demonstrated between water hardness and conductivity.
- **Do not treat water with softeners!** This could cause corrosion of the electrodes or the formation of foam, leading to potential operating problems or failures.
- Do not add disinfectants or corrosion inhibitors to water, as these substances are potentially irritant.
- Is absolutely forbidden to use well water, industrial water or water drawn from cooling circuits; in general, avoid using potentially contaminated water, either from a chemical or bacteriological point of view

TECHNICAL DATA

MODEL		007 P1	009 P1	011 P1	014 P1	016 P1	020 P1
SIZE		E1	E1	E1	E2	E2	E3
VERSION (1)		DL	DL	DL	DL	DL	DL
VAPOUR PRODUCTION	kg/h	---	---	---	---	---	3,0
Power input	kW	---	---	---	---	---	2,3
Absorbed current (OA)	A	---	---	---	---	---	3,2
Max absorbed current (FLA)	A	---	---	---	---	---	4,5
Water content	l	---	---	---	---	---	3,9
Max water supply pressure	Bar	---	---	---	---	---	1÷8
NET WEIGHT (2)	kg	---	---	---	---	---	6
HYDRAULIC CONNECTION							
WATER INLET - ISO 7/1 - R	Ø	---	---	---	---	---	3/4"

1. DL = Displacement air delivery

2. Value to be added to the weight of the standard unit. Does not include the weight of the water content.

TECHNICAL DATA

MODEL		022 P1	026 P1	032 P1	037 P1	041 P1
SIZE		E3	E3	E4	E4	E4
VERSION (1)		DL	DL	DL	DL	DL
VAPOUR PRODUCTION	kg/h	3,0	3,0	8,0	8,0	8,0
Power input	kW	2,3	2,3	6,0	6,0	6,0
Absorbed current (OA)	A	3,2	3,2	8,7	8,7	8,7
Max absorbed current (FLA)	A	4,5	4,5	12,4	12,4	12,4
Water content	l	3,9	3,9	6,4	6,4	6,4
Max water supply pressure	Bar	1÷8	1÷8	1÷8	1÷8	1÷8
NET WEIGHT (2)	kg	6	6	10	10	10
HYDRAULIC CONNECTION						
WATER INLET - ISO 7/1 - R	Ø	3/4"	3/4"	3/4"	3/4"	3/4"

- DL = Displacement air delivery
- Value to be added to the weight of the standard unit. Does not include the weight of the water content.

OVERSIZED HUMIDIFIERS

The optional is not available for size E1, E2.
On request, it is possible to install the oversized humidifiers system.
The components are the same of the standard accessory

TECHNICAL DATA

MODEL		007 P1	009 P1	011 P1	014 P1	016 P1	020 P1
SIZE		E1	E1	E1	E2	E2	E3
VERSION (1)		DL	DL	DL	DL	DL	DL
VAPOUR PRODUCTION	kg/h	---	---	---	---	---	8,0
Power input	kW	---	---	---	---	---	6,0
Absorbed current (OA)	A	---	---	---	---	---	8,7
Max absorbed current (FLA)	A	---	---	---	---	---	12,4
Water content	l	---	---	---	---	---	6,4
Max water supply pressure	Bar	---	---	---	---	---	1÷8
NET WEIGHT (2)	kg	---	---	---	---	---	10
HYDRAULIC CONNECTION							
WATER INLET - ISO 7/1 - R	Ø	---	---	---	---	---	3/4"

MODEL		022 P1	026 P1	032 P1	037 P1	041 P1
SIZE		E3	E3	E4	E4	E4
VERSION (1)		DL	DL	DL	DL	DL
VAPOUR PRODUCTION	kg/h	8,0	8,0	15,0	15,0	15,0
Power input	kW	6,0	6,0	11,3	11,3	11,3
Absorbed current (OA)	A	8,7	8,7	16,2	16,2	16,2
Max absorbed current (FLA)	A	12,4	12,4	23,0	23,0	23,0
Water content	l	6,4	6,4	10,3	10,3	10,3
Max water supply pressure	Bar	1÷8	1÷8	1÷8	1÷8	1÷8
NET WEIGHT (2)	kg	10	10	16	16	16
HYDRAULIC CONNECTION						
WATER INLET - ISO 7/1 - R	Ø	3/4"	3/4"	3/4"	3/4"	3/4"

- DL = Displacement air delivery
- Value to be added to the weight of the standard unit. Does not include the weight of the water content.

OPTIONAL ACCESSORIES – DEHUMIDIFICATION SYSTEM

Components:

- Temperature / Humidity sensor on the air intake.
- Electronic control system of the dew point temperature for the combined intervention of cooling capacity and air flow.
- Electronic expansion valve



OPTIONAL ACCESSORIES – ELECTRIC HEATERS



Electric heater consisting of finned aluminum elements, ensuring low surface temperature and deleting the air ionization problems. The optional is installed downstream the main cooling coil.

In electric heaters with three working steps the activation is binary type.

Components:

- Electric heater in aluminium armoured elements with integral fins
- Electrical control
- Safety thermostat.

TECHNICAL DATA

MODEL		007 P1	009 P1	011 P1	014 P1	016 P1	020 P1
SIZE		E1	E1	E1	E2	E2	E3
VERSION (1)		DL	DL	DL	DL	DL	DL
THERMAL CAPACITY	kW	5,1	5,1	5,1	5,1	5,1	6,0
Absorbed current (OA)	A	7,4	7,4	7,4	7,4	7,4	8,7
First working step	kW	5,1	5,1	5,1	5,1	5,1	3,0
Second working step	kW	--	--	--	--	--	3,0+3,0
Third working step	kW	--	--	--	--	--	--
NET WEIGHT (2)	kg	4	4	4	4	4	7

MODEL		022 P1	026 P1	032 P1	037 P1	041 P1
SIZE		E3	E3	E4	E4	E4
VERSION (1)		DL	DL	DL	DL	DL
THERMAL CAPACITY	kW	6,0	6,0	9,0	9,0	9,0
Absorbed current (OA)	A	8,7	8,7	13,0	13,0	13,0
First working step	kW	3,0	3,0	3,0	3,0	3,0
Second working step	kW	3,0+3,0	3,0+3,0	6,0	6,0	6,0
Third working step	kW	--	--	3,0+6,0	3,0+6,0	3,0+6,0
NET WEIGHT (2)	kg	7	7	9,5	9,5	9,5

OVERSIZED ELECTRIC HEATERS

The optional is not available for size E1, E2.

On request, it is possible to install the oversized electric heating system.

The components are the same of the standard accessory

TECHNICAL DATA

MODEL		007 P1	009 P1	011 P1	014 P1	016 P1	020 P1
SIZE		E1	E1	E1	E2	E2	E3
VERSION (1)		DL	DL	DL	DL	DL	DL
THERMAL CAPACITY	kW	--	--	--	--	--	9,0
Absorbed current (OA)	A	--	--	--	--	--	13,0
First working step	kW	--	--	--	--	--	4,5
Second working step	kW	--	--	--	--	--	4,5+4,5
Third working step	kW	--	--	--	--	--	--
NET WEIGHT (2)	kg	--	--	--	--	--	7

MODEL		022 P1	026 P1	032 P1	037 P1	041 P1
SIZE		E3	E3	E4	E4	E4
VERSION (1)		DL	DL	DL	DL	DL
THERMAL CAPACITY	kW	9,0	9,0	13,5	13,5	13,5
Absorbed current (OA)	A	13,0	13,0	19,5	19,5	19,5
First working step	kW	4,5	4,5	4,5	4,5	4,5
Second working step	kW	4,5+4,5	4,5+4,5	9,0	9,0	9,0
Third working step	kW	--	--	4,5+9,0	4,5+9,0	4,5+9,0
NET WEIGHT (2)	kg	7	7	9,5	9,5	9,5

1. DL = Displacement air delivery
2. Value to be added to the weight of the standard unit.

OPTIONAL ACCESSORIES – ePM₁₀ 50% EFFICIENCY AIR FILTERS

The ePM₁₀ 50% air filters (according to ISO EN 16890), replace the standard one. The filters generate a pressure drops higher than the standard ones. The filters are made of glass micro-fibre and are not regenerable.

MODEL		007 P1	009 P1	011 P1	014 P1	016 P1	020 P1
SIZE		E1	E1	E1	E2	E2	E3
VERSION (1)		DL	DL	DL	DL	DL	DL
Additional pressure drops (2)	Pa	42	49	53	65	71	55

MODEL		022 P1	026 P1	032 P1	037 P1	041 P1
SIZE		E3	E3	E4	E4	E4
VERSION (1)		DL	DL	DL	DL	DL
Additional pressure drops (2)	Pa	62	69	29	29	42

- DL = Displacement air delivery
- Additional pressure drops referred to nominal air flow and clean filter.

OPTIONAL ACCESSORIES - FLOOR STAND

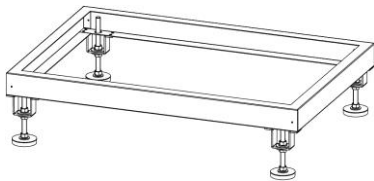

The accessory is supplied as an assembly kit. For a correct installation of the air conditioner we suggest you to utilize a gasket between the floor stand and the unit base. The floor stand is available in 3 different heights.

SIZE E1 - E2 - E3 - E4

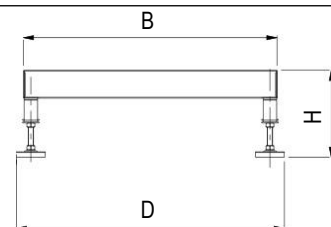
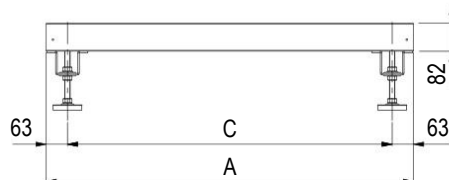

SIZE		E1	E2	E3	E4
A	mm	650	785	1085	1305
B	mm	650	650	750	905
C	mm	524	659	959	955
D	mm	691	691	791	945

MODEL		Hmax350	Hmax450	Hmax510
H min height	mm	255	355	400
H max height	mm	350	450	510

OPTIONAL ACCESSORIES – DIRECT FREE-COOLING PLENUM

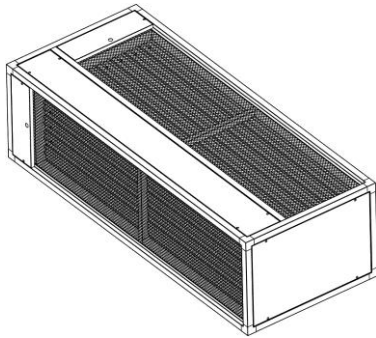

For a further energy-saving, the conditioners are equipped with a proportional automatic free-cooling system in order to obtain free cooling when the indoor temperature is higher than outdoor one. Practically, the fresh air is used as coolant, when the outside conditions allow for this, in order to cool the ambient.

The cooling system is fully proportional and allows three working modes:

- total free-cooling: only fresh air is used to cool the ambient
- partial free-cooling: the fresh air is used for a pre-cooling and the compressor is used to balance the load.
- mechanical cooling: the compressor is used to cool the ambient.

The fresh air input into the room causes an internal pressure increase, that must be avoided to grant a correct performance of the plant.

For this reason, it is necessary to install an overpressure damper close to the ceiling, to allow the hot air discharge.

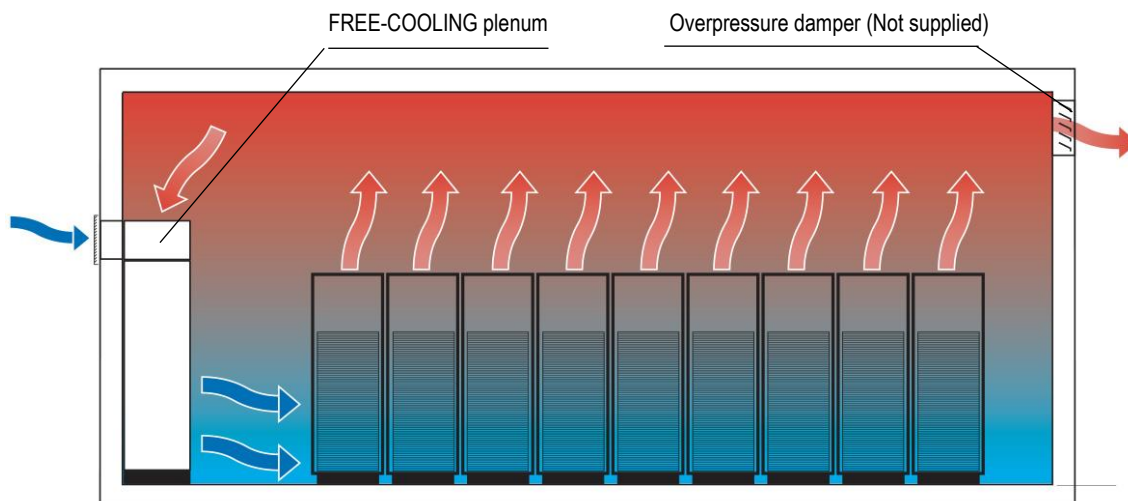

The optional is supplied separately and the installation on the unit is at Customer care.

The plenums have same technical characteristics and base dimensions of the machine cabinet.

The optional allow to obtain free-cooling by direct ambient air intake into the room.

The dampers are proportionally managed by the microprocessor control, that regulates the quantity of the ambient air to put in the room according to the set-point.

FRAMEWORK

- Frame in aluminium extrusion, painted with epoxy powders. Colour RAL 9005;
- Panels in galvanized steel sheet with protective surfaces treatment in compliance with UNI ISO 9227/ASTMB117 and ISO 7253, and painted with epoxy powders. Colour RAL 9005;
- Panels insulated with polyurethane foam and seals to ensure air tight.
- Panels fixed with screws.
- Removable panels.
- Opposed blade dampers in galvanized steel sheet and safety grille for ambient air and room air suction.
- Actuator for each damper.
- Terminals for electric connection to the unit.
- Combined Temperature / Humidity sensor on machine air suction. The sensor must be moved outside the air conditioners for a proper read of the room temperature value.
- Temperature sensor for outdoor air. The sensor must be installed in the outdoor air suction duct or anyway protected against atmospheric agent.
- Free contact for free-cooling operating status monitoring.
- Set of fixing elements to fasten the plenum to the unit.

WARNING

IT IS COMPULSORY TO INSTALL INTO THE ROOM AN APPROPRIATELY SIZED OVERPRESSURE DAMPER TO ALLOW THE ROOM AIR EXHAUSTION DURING FREE-COOLING WORKING MODE.

INSTALLATION EXAMPLE

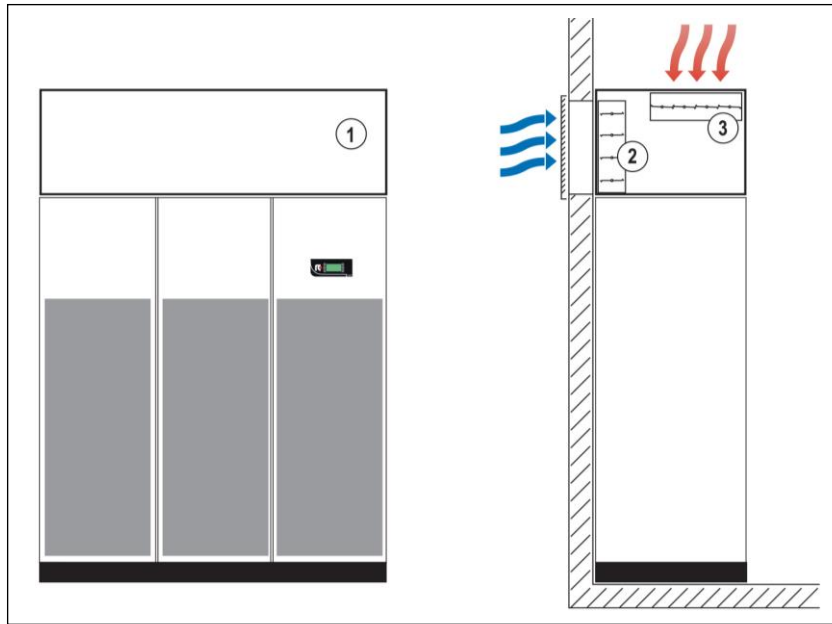

- 1. Free-Cooling plenum;
- 2. Ambient air damper;
- 3. Return air damper

Ducting are at Customer care.
We suggest you to install a rain-proof grille on ambient air intake.

FREE-COOLING PLENUM – SIZE E1

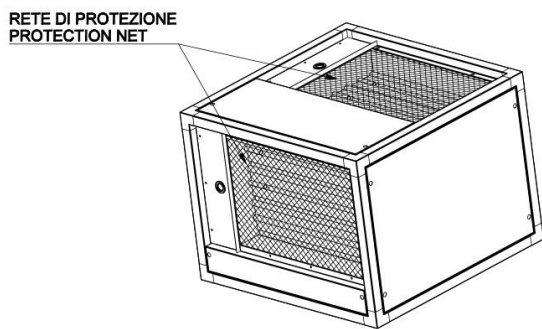
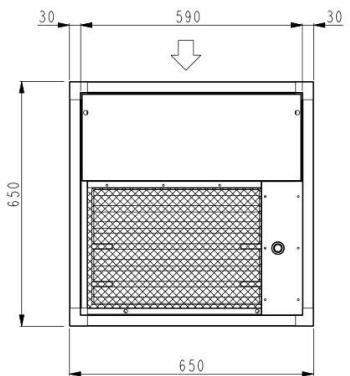
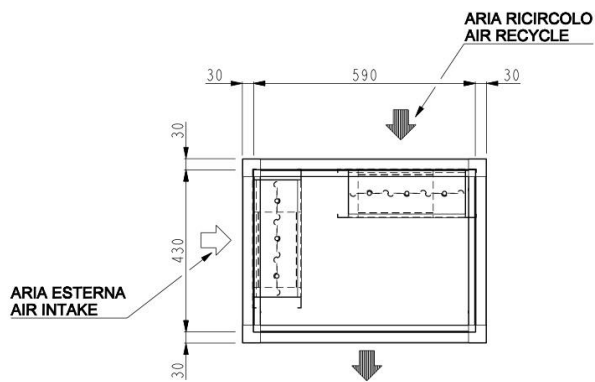
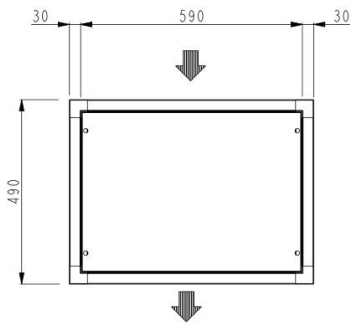

Size	E1
Weight	kg 24

Add this value to the total unit weight

FREE-COOLING PLENUM - SIZE E2

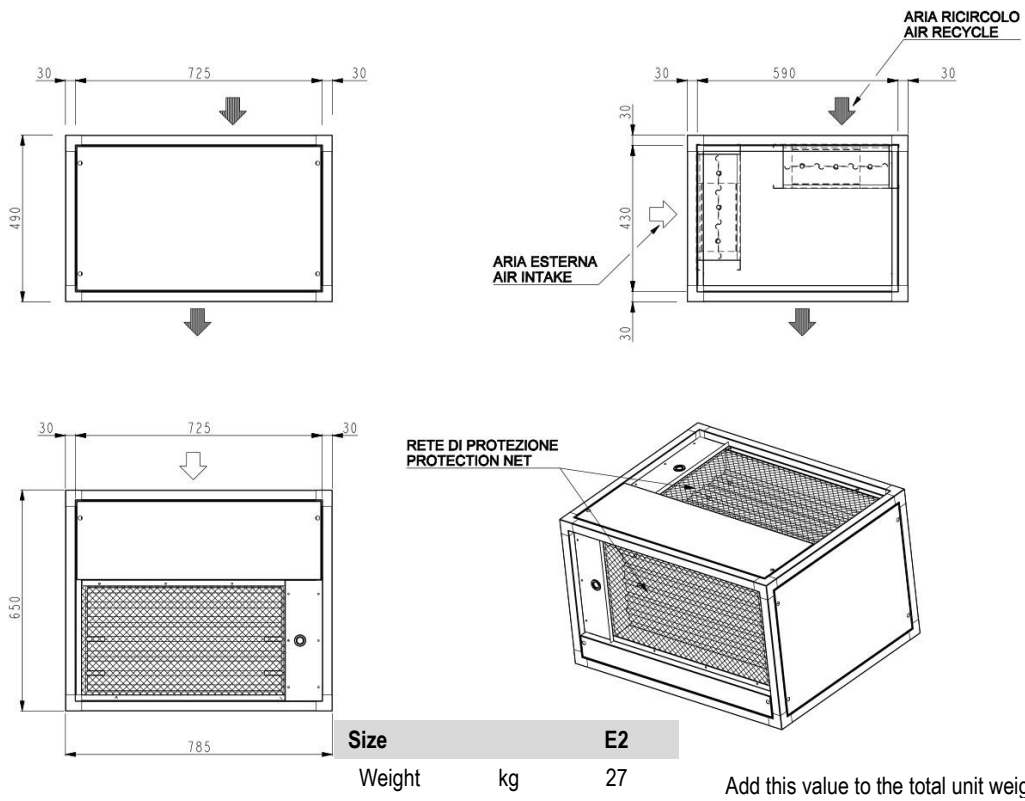

FREE-COOLING PLENUM - SIZE E3

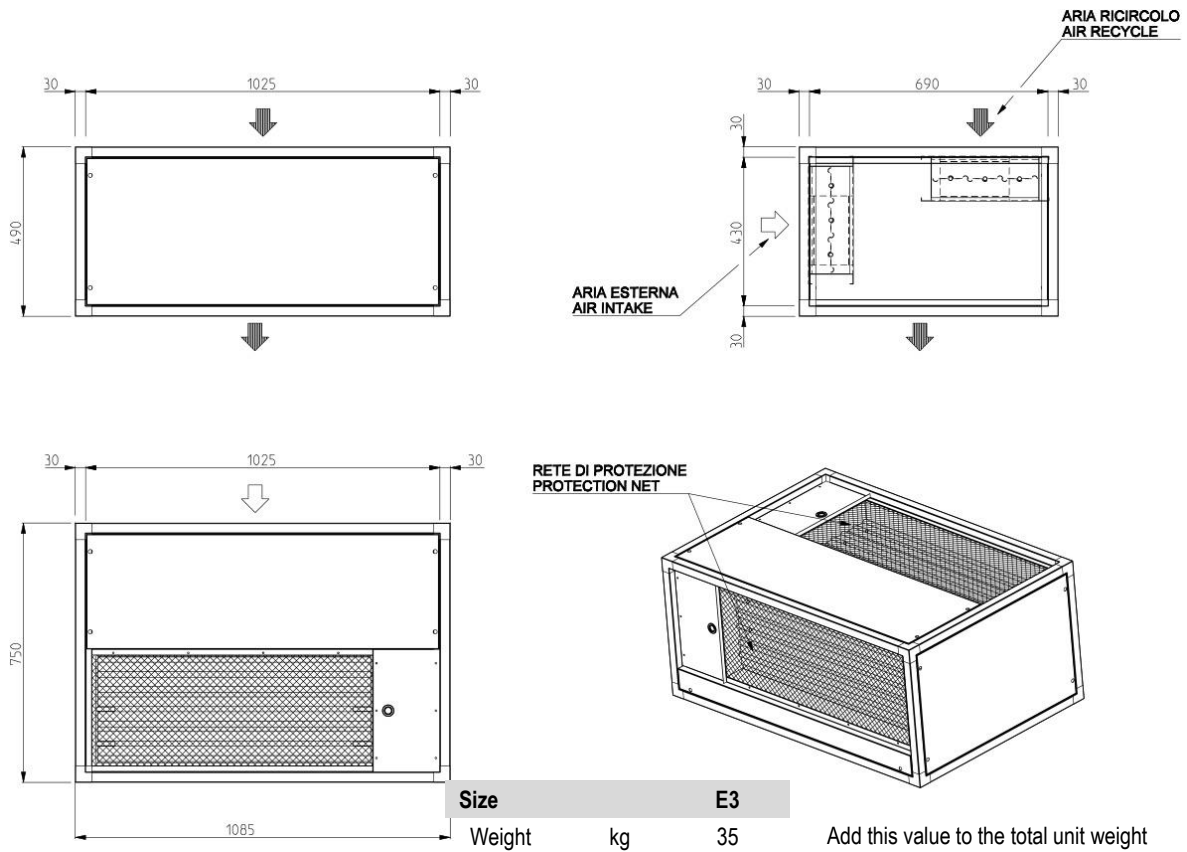

FREE-COOLING PLENUM - SIZE E4

Size	E4	
Weight	kg	58

Add this value to the total unit weight

OPTIONAL ACCESSORIES – KIPlink – Keyboard in your Pocket



KIPlink - Keyboard In Your Pocket - is the innovative user interface based on WiFi technology that allows one to operate on the unit directly from the smartphone or tablet. Using KIPlink, it is possible to turn the unit on and off, adjust the set-point, plot the main operating variables, monitor in detail the status of the refrigerant circuits, the compressors, the fans and display and reset the possible alarms.

Scan the QR code on the electrical board of the unit to have access to the unit control through web browser web or App. The access is possible within the local WiFi network.

KIPlink hardware:

- Wi-Fi antenna in the electrical board;
- ON/OFF button with power LED and Unit status LED. Provided when the unit is equipped with KIPlink and without 6-keys keyboard (optional).

KIPlink allows;

- Easy and enhanced unit management
- Real-Time graphs and key trends
- Different information for each kind of user

OPTIONAL ACCESSORIES – CLOUD PLATFORM: WEB SERVICES BASED ON CLOUD TECHNOLOGY FOR REMOTE MONITORING AND MANAGEMENT OF AIR CONDITIONING PLANTS.



CLOUD PLATFORM is an ecosystem of web services for remote monitoring and management of air conditioning plants; specifically designed for mobile usage on tablets and smartphones, it allows to access plant data everywhere on the go so saving time, money and delivering a higher service level to the customer.

TECHNOLOGY

Based on cloud technology it allows, through machines data telemetry, to monitor and control units on the field, process data and perform proactive maintenance.

The hardware heart of the system is the Cloud box that can collect plant data (up to 31 devices and up to 1000 registers).

Connectivity between monitored devices and Cloud box may be wired in Ethernet, RS485, RS232 and must be in MODBUS protocol.

Cloud Platform then send these data to dedicated server in cloud in through the mobile (GPRS or 3G) network or ADSL.

Information security; each communication channel can be encrypted in VPN, ensuring data privacy.

USER SIDE

Cloud Platform is designed for mobile communication. So, the user just need a tablet or a smartphone to access the RC Cloud Platform and check his plant.

Cloud Platform App is available both on Android and iOS operating systems so the environment may be accessed directly from them beyond company site and platform site. Access through pc is available too.

FUNCTIONS

Telemetry & Data Export

Data polling and history of all data (1 year).
Export diagram and table (csv). **Your data always on the go.**

Multi Device

Many type of devices can be connected to the same box (chillers, close control, energy meters, flow meters, pumps,...).

Only a request: MODBUS protocol. Electrical connection in Ethernet, RS 485 or RS 232.

Multi Language

English native, Cloud Platform language pack is available for the main markets.

Virtual Display

Monitoring and control (on/off, alerts reset, main parameters change) as being beside the unit, in an augmented reality way.

Designed for Mobile.

Same as standing in front of the unit, when in your office or in any other place.

Internet Connectivity

ETHERNET + GPRS + 3G connection capability on Public and Virtual Private Network (VPN).

Alerts Warning through:

- Push notification
- e-mail
- Voice calls
- SMS

Processing of specialized plant KPI to get:

- Energy performance (gross instant EER)
- Components Failure Forecast (coming soon)
- Unit diagnosis

MACHINE DRAWINGS

Dimensions in mm – SIZE E1

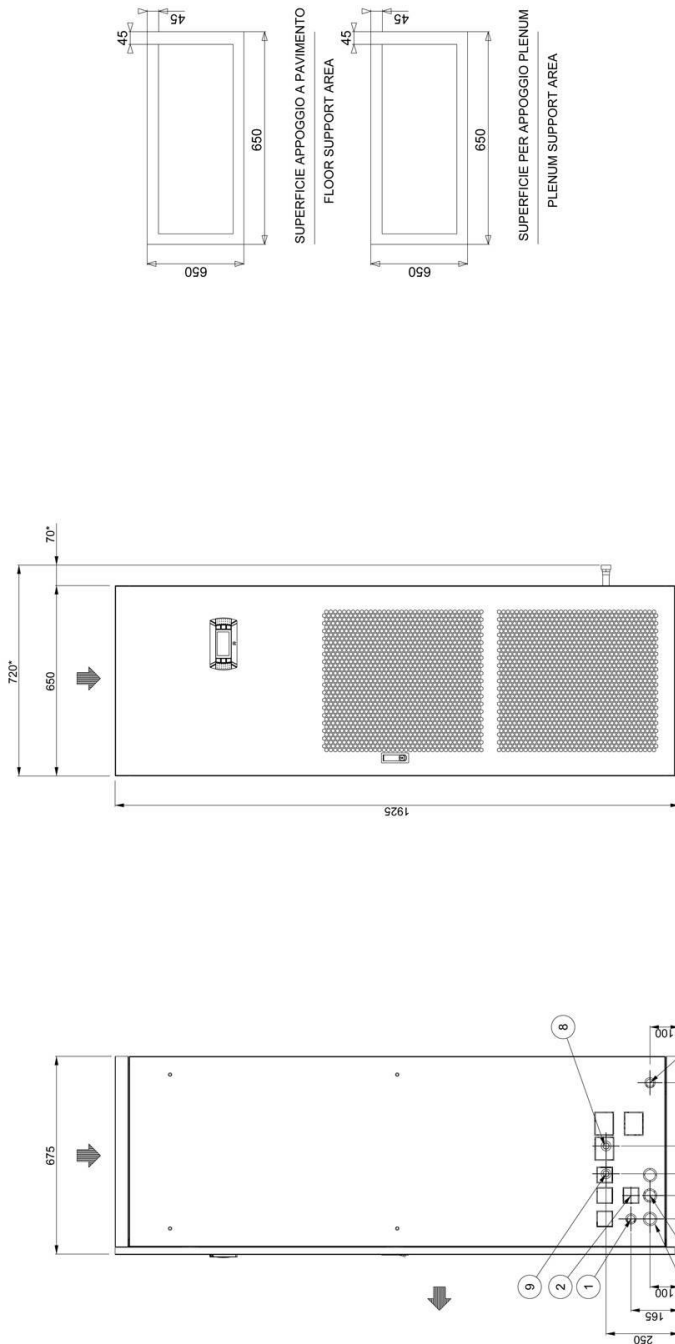

SUPERFICIE APPOGGIO A PAVIMENTO

FLOOR SUPPORT AREA

SUPERFICIE PER APPOGGIO PLENUM

PLENUM SUPPORT AREA

*: QUOTE SOLO PER MODELLO CW.
DIMENSIONS ONLY FOR MODEL CW

CONNESSIONI / CONNECTIONS		w-NEXT DL DX
9	USCITA ACQUA REFRIGERATA R.1	CHILLED WATER OUTLET R.1
8	INGRESSO ACQUA REFRIGERATA R.1	CHILLED WATER INLET R.1
5	ALIMENTAZIONE ELETTRICA	POWER SUPPLY
4	SCARICO ACQUA UMIDIFICATORE Ø 3/4"	HUMIDIFIER DRAIN Ø 3/4"
3	SCARICO CONDENSATA Ø 18mm.	CONDENSATE DISCHARGE Ø 18mm.

CONNESSIONI / CONNECTIONS		t-NEXT DL DX
5	ALIMENTAZIONE ELETTRICA	POWER SUPPLY
4	CARICO ACQUA UMIDIFICATORE Ø 3/4"	HUMIDIFIER FILL Ø 3/4"
3	SCARICO CONDENSATA Ø 18mm.	CONDENSATE DISCHARGE Ø 18mm.
2	RITORNO LIQUIDO Ø 12mm. ODS	LIQUID RETURN Ø 12mm. ODS
1	MANDATA GAS Ø 12mm. ODS Mod.007-009-011 P1	GAS DELIVERY Ø 12mm. ODS Mod.007-009-011 P1

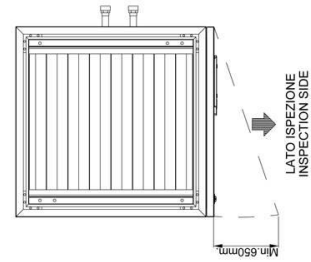

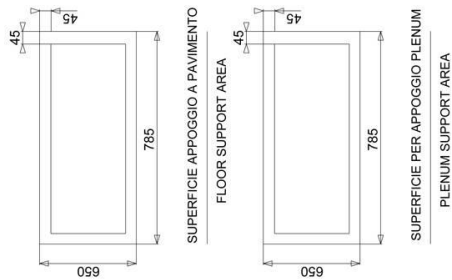
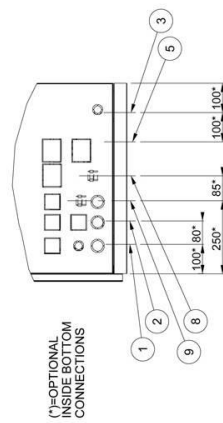
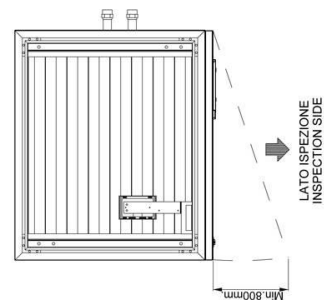
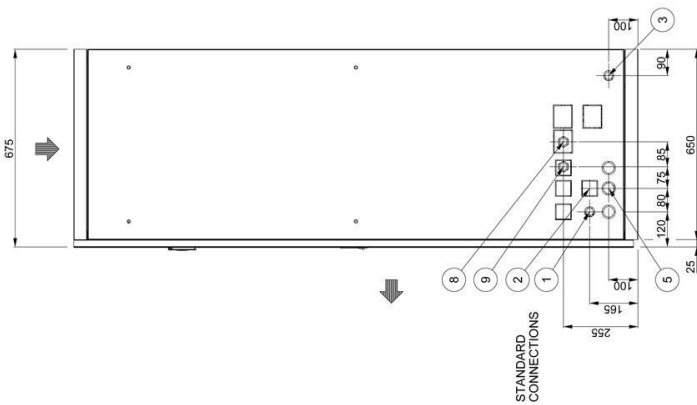
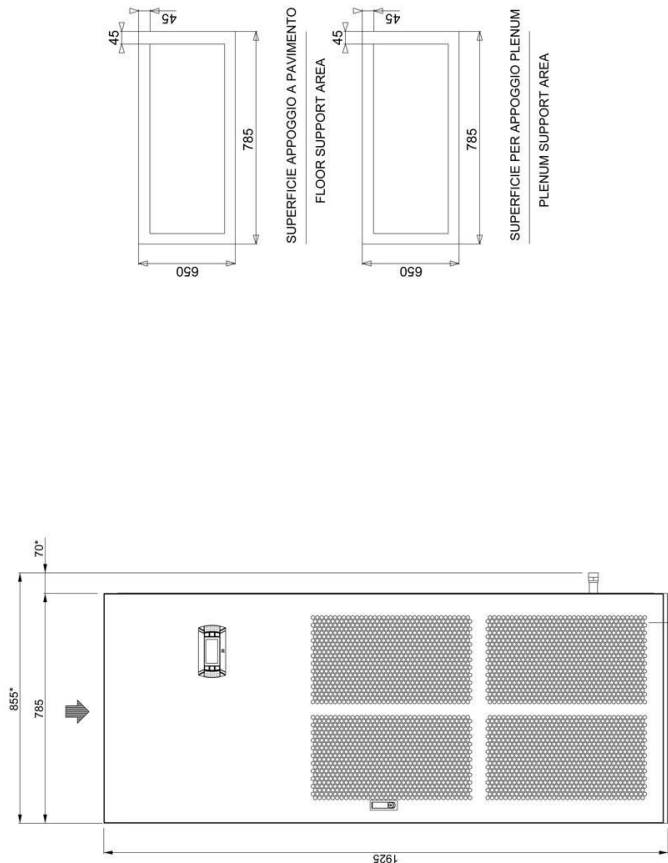

*: QUOTE SOLO PER MODELLO CW.
DIMENSIONS ONLY FOR MODEL CW

CONNESSIONI / CONNECTIONS w-NEXT DX DL	
9	USCITA ACQUA REFRIGERATA R.1 CHILLED WATER OUTLET R.1
8	INGRESSO ACQUA REFRIGERATA R.1 CHILLED WATER INLET R.1
5	ALIMENTAZIONE ELETTRICA POWER SUPPLY
4	SCARICO ACQUA UMIDIFICATORE Ø 19mm HUMIDIFIER DRAIN Ø 19mm
3	SCARICO CONDENSATE Ø 19mm CONDENSATE DISCHARGE Ø 19mm

CONNESSIONI / CONNECTIONS t/-NEXT DX DL	
5	ALIMENTAZIONE ELETTRICA POWER SUPPLY
4	SCARICO ACQUA UMIDIFICATORE Ø 19mm HUMIDIFIER DRAIN Ø 19mm
3	SCARICO CONDENSATE Ø 19mm CONDENSATE DISCHARGE Ø 19mm
2	RITORNO LIQUIDO Ø 12mm. ODS LIQUID RETURN Ø 12mm. ODS
1	MANDATA GAS Ø 19mm. ODS GAS DELIVERY Ø 19mm. ODS

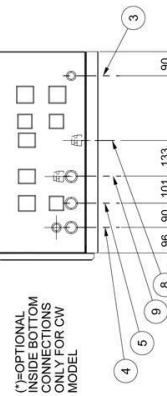
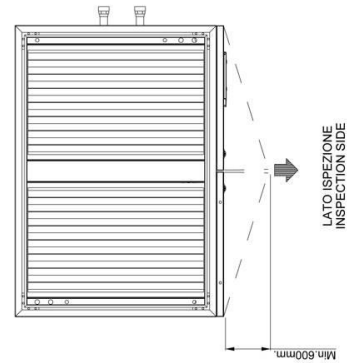
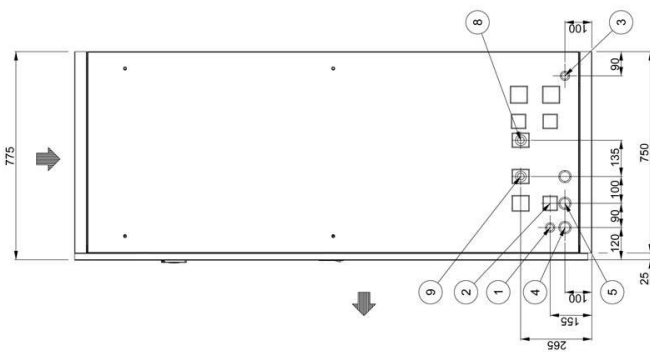
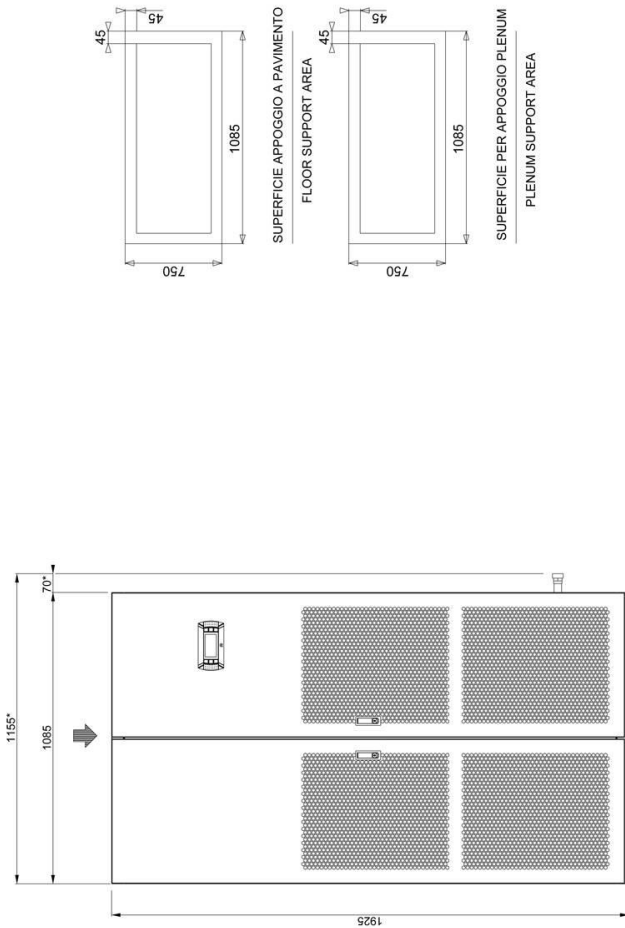

CONNESSIONI / CONNECTIONS		w-NEXT DX DL
9	USCITA ACQUA REFRIGERATA R.1/4	CHILLED WATER OUTLET R.1/4
8	INGRESSO ACQUA REFRIGERATA R.1/4	CHILLED WATER INLET R.1/4
5	ALIMENTAZIONE ELETTRICA	POWER SUPPLY
4	SCARICO ACQUA UMIDIFICATORE Ø 3/4"	HUMIDIFIER DRAIN Ø 3/4"
3	SCARICO ACQUA UMIDIFICATORE Ø 1"	HUMIDIFIER DRAIN Ø 1"
2	SCARICO CONDENSATO Ø 18mm	CONDENSATE DISCHARGE Ø 18mm

CONNESSIONI / CONNECTIONS		t/i-NEXT DX DL
5	ALIMENTAZIONE ELETTRICA	POWER SUPPLY
4	CARICO ACQUA UMIDIFICATORE Ø 3/4"	HUMIDIFIER FILL G. 3/4"
3	SCARICO ACQUA UMIDIFICATORE Ø 1"	HUMIDIFIER DRAIN Ø 1"
2	SCARICO CONDENSATO Ø 18mm	CONDENSATE DISCHARGE Ø 18mm
1	MANDATA GAS Ø 18mm	GAS DELIVERY Ø 18mm
	MANDATA GAS Ø 18mm	GAS DELIVERY Ø 18mm
	MANDATA GAS Ø 18mm	GAS DELIVERY Ø 18mm
	MANDATA GAS Ø 18mm	GAS DELIVERY Ø 18mm

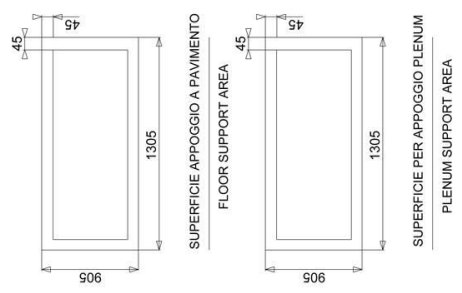
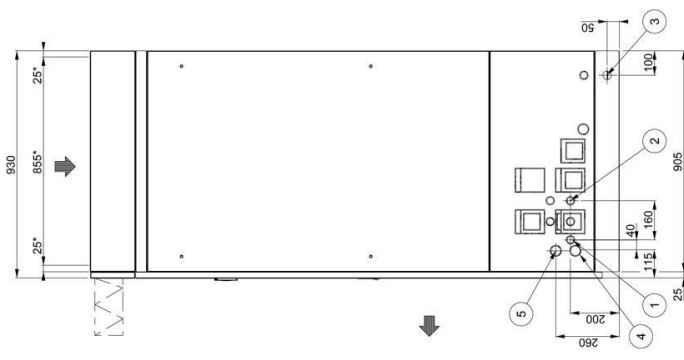
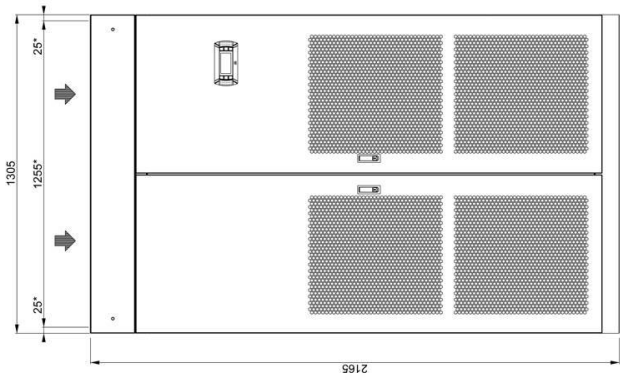

*: QUOTE PER CANALE DI ASPIRAZIONE ARIA
DIMENSIONS FOR AIR INTAKE DUCT

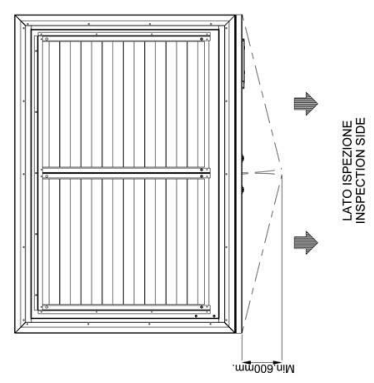

CONNESSIONI / CONNECTIONS		I / -NEXT DX DL
5	ALIMENTAZIONE ELETTRICA / POWER SUPPLY	3x 2.5mm ² / 3x 10A
4	SCARICO ACQUA / HUMIDIFIER DRAIN	Ø 18mm
3	SCARICO CONDENSATO / CONDENSATE DISCHARGE	Ø 18mm
2	RITORNO LIQUIDO / LIQUID RETURN	Ø 18mm / 30 M1
1	MANDATA GAS / GAS DELIVERY	Ø 18mm / 30 M1



MITSUBISHI ELECTRIC HYDRONICS & IT COOLING SYSTEMS S.p.A.

Via Caduti di Cefalonia, 1 - 36061 Bassano del Grappa (VI) Italy
Ph. (+39) 0424 509 500 • Fax (+39) 0424 509 509
www.melcohit.com